



BERTH LIGHT WITH SWITCH AND SWIVELING REFLECTOR FOR INSTALLATION IN ACCOMMODATION AREAS

Design	According to rules of maritime classification societies and relevant standards
Housing	Galvanized steel, powder coated white (RAL9016)
End caps	Polycarbonate, white
Reflector	Galvanized steel, powder coated white (RAL9016)
Switch	On / off switch, 2-pole
Mounting	2 mounting holes, Ø 5.5 mm
Cable entry	1 inlet for cables max. Ø 11 mm
Protection class	IP20
Weight	Type A: 0.8 kg Type B: 1.0 kg
Light source	LED (lamp not included)
Lamp base	E27
Wattage	Max. 40 W
Voltage	220–240 V AC or 110–120 V AC
Frequency	50–60 Hz

PART NO.

KJ15 Type A	5117000300-003
KJ15 Type B	5117000400-003

SPARE PARTS

PART NO.

End caps	7112018600
----------	------------

Type A

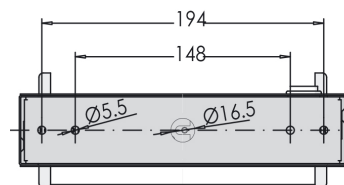
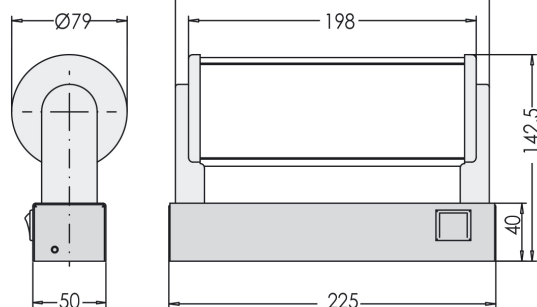

Type B

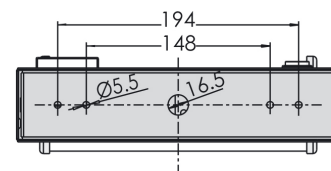
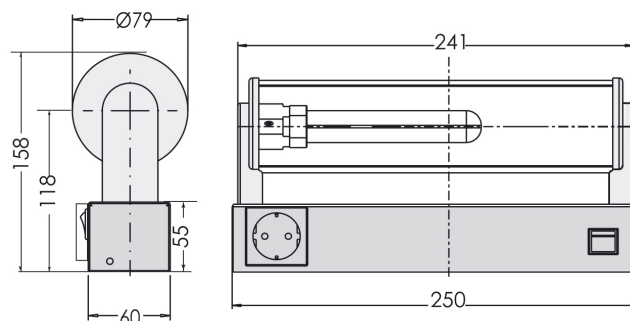

[mm]

