



ILLUMINATED LED SIGN FOR DECKS, STORES
AND ENGINE ROOMS

Design	According to rules of maritime classification societies and relevant standards
Housing	Steel, zinc plated powder coated white (RAL9016)
Cover	Opal polycarbonate, foil included
Mounting	2 mounting holes, Ø 9 mm
Cable entry	2 cable glands M20x1.5, brass for cables Ø 6–13 mm
Connection type	Terminal 3-pole (under cable entry)
Protection class	IP67
Weight	1.5 kg
Light source	Linear LP LED module
Wattage	Max. 4 W
CCT (color)	4,000 K
CRI	≥ 80
Voltage	220–240 V AC
Frequency	50–60 Hz

PART NO.

TL09 Sign

5122004400-002

★ EXTRAS

- > 120 V AC execution
- > 24 V DC execution
- > Stainless steel housing
- > Emergency battery back-up, with test switch, 1 W
- > Different cable glands
- > Different pictograms on customer requirements

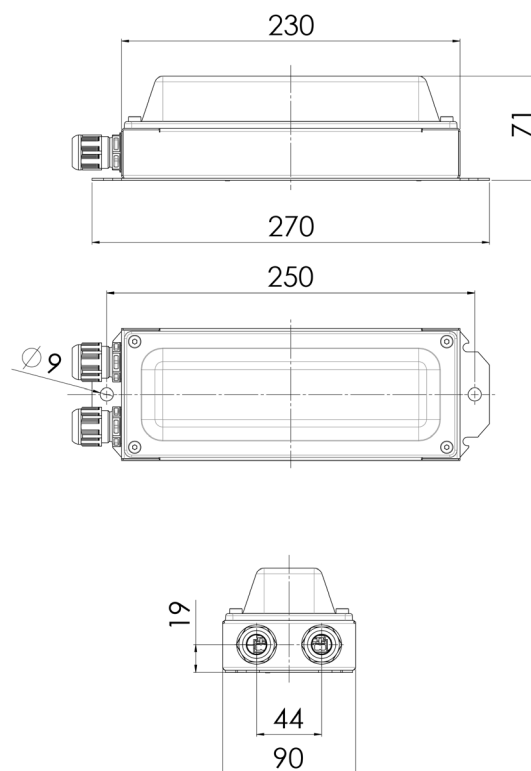

[mm]

