

## DE29

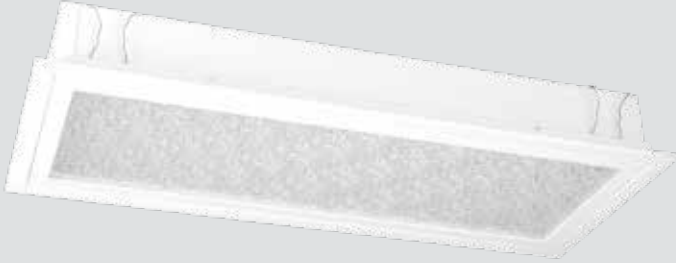

RECESSED MOUNTED CEILING LUMINAIRE  
FOR ACCOMMODATION AND PUBLIC AREAS

<b>Design</b>	According to rules of maritime classification societies and relevant standards
<b>Housing</b>	Galvanized steel, powder coated white (RAL9016)
<b>Diffuser</b>	Clear polycarbonate with ice crystal structure
<b>Mounting</b>	Mounting set for ceilings 23-55 mm
<b>Cable entry</b>	2 inlets for cables max. Ø 13 mm
<b>Protection class</b>	IP20 / IP44 in conjunction with ceiling, IP20 with louver
<b>Voltage</b>	220-240 V AC
<b>Frequency</b>	50-60 Hz

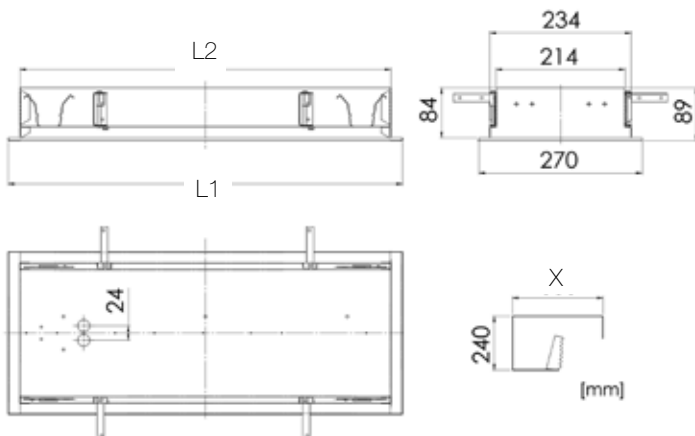

### LED SOLUTION

DE29S	5111009110-xxx
DE29L	5111009010-xxx
Light source	Linear LP LED modules
Wattage	Max. 20 W / max. 40 W
CCT (color)	3,000 K or 4,000 K
Luminous flux	DE29S: 1,500 lm DE29L: 3,100 lm
CRI	≥ 80
Weight	4.0 kg (DE29S) 7.0 kg (DE29L)

### FLUORESCENT SOLUTION

DE29 2x 18 W	5111005400-023
DE29 2x 36 W	5111005900-013
Light source	T8 fluorescent tubes (not included)
Wattage	2x 18 W 2x 36 W
Lamp base	G13
Weight	4.0 kg (DE29 2x 18 W) 7.0 kg (DE29 2x 36 W)

### SPARE PARTS

### PART NO.

Icecrystal cover (DE29S)	7931000900
Icecrystal cover (DE29L)	7931002000

### ★ EXTRAS

- > 120 V AC execution
- > 24 V DC execution
- > Dimmable
- > Emergency battery back-up
- > Alternative housing colors
- > Different louvers and diffusers
- > Different mounting sets

TYPE	L1	L2	X
DE29S	652	614	635
DE29L	1246	1225	1235