



BERTH LIGHT WITH SWITCH AND SWIVELING REFLECTOR FOR CABINS AND ACCOMMODATION AREAS

### STANDARD CONFIGURATION

Housing	Galvanized steel, powder coated white (RAL9016)
Reflector	Galvanized steel, powder coated white (RAL9016)
Mounting	2 holes, Ø 5.5 mm
Cable entry	2 EMC grommets
Protection class	IP20
Lamp base	E27
Wattage	Max. 40W

### AVAILABLE FEATURES



Shock proof



Vibration resistant

### YOUR REQUIREMENTS

Please contact us for different configurations or further information on this luminaire type. Based on your requirements, the final part number will be provided.

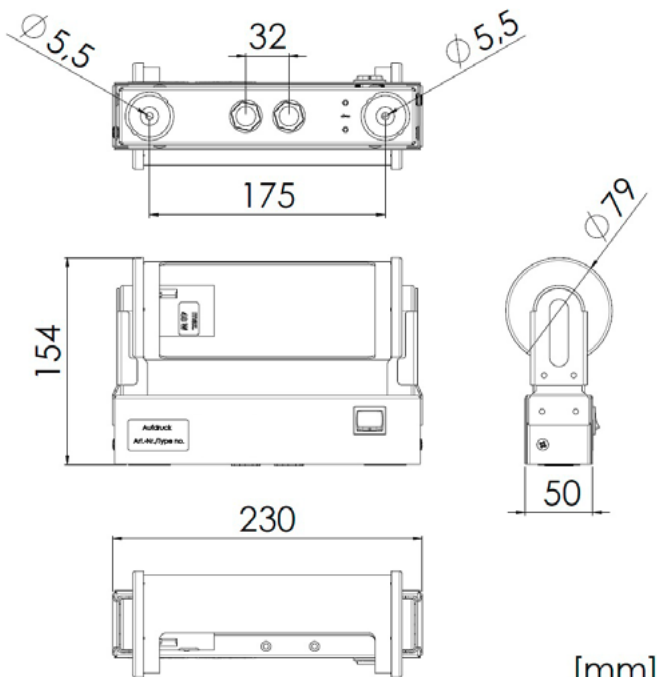

[mm]  
MB6.117.0003.02

Technical modification reserved without prior notice.



LIGHTPARTNER LICHTSYSTEME GMBH & CO. KG  
AM MOHRENSHOF 7 · 28277 BREMEN · GERMANY  
+49 (0)421 - 87 195 - 0 · SALES@LIGHTPARTNER.DE

# LIGHTPARTNER NAVY